



Part no.	IX2203
Recommended for	3G
Product Name	3G Pentaband antenna screw mount with 3m cable, IP67
Feature	3 meter low loss cable NFC-200 SMA(M) Low profile, height just 19.5mm and diameter 55mm Heavy duty screw mount UV and vandal resistant PC housing and thread 800 MHz to 2200 MHz GSM/CDMA/HSPA/UMTS Extended operation temperature range IP67 compliant RoHS compliant

Electrical

Communication system	AMPS	GSM	DCS	PCS	UMTS
Frequency (MHz)	824- 896	880-960	1710-1880	1850-1990	1710-2170
Efficiency*	39.1%	39.3%	53.4%	52.5%	53.4%
Gain (dBi)	2.0	1.8	3.9	3.9	3.9
Impedance	50 Ω				
Polarization	Linear				
Radiation Pattern	Omni-directional				
Input power	10 W				

*in free space

Environmental

Temperature range	-40°C to 85°C
Casing	Non-condensing 65°C 95% RH

Mechanical drawing (unit:mm)

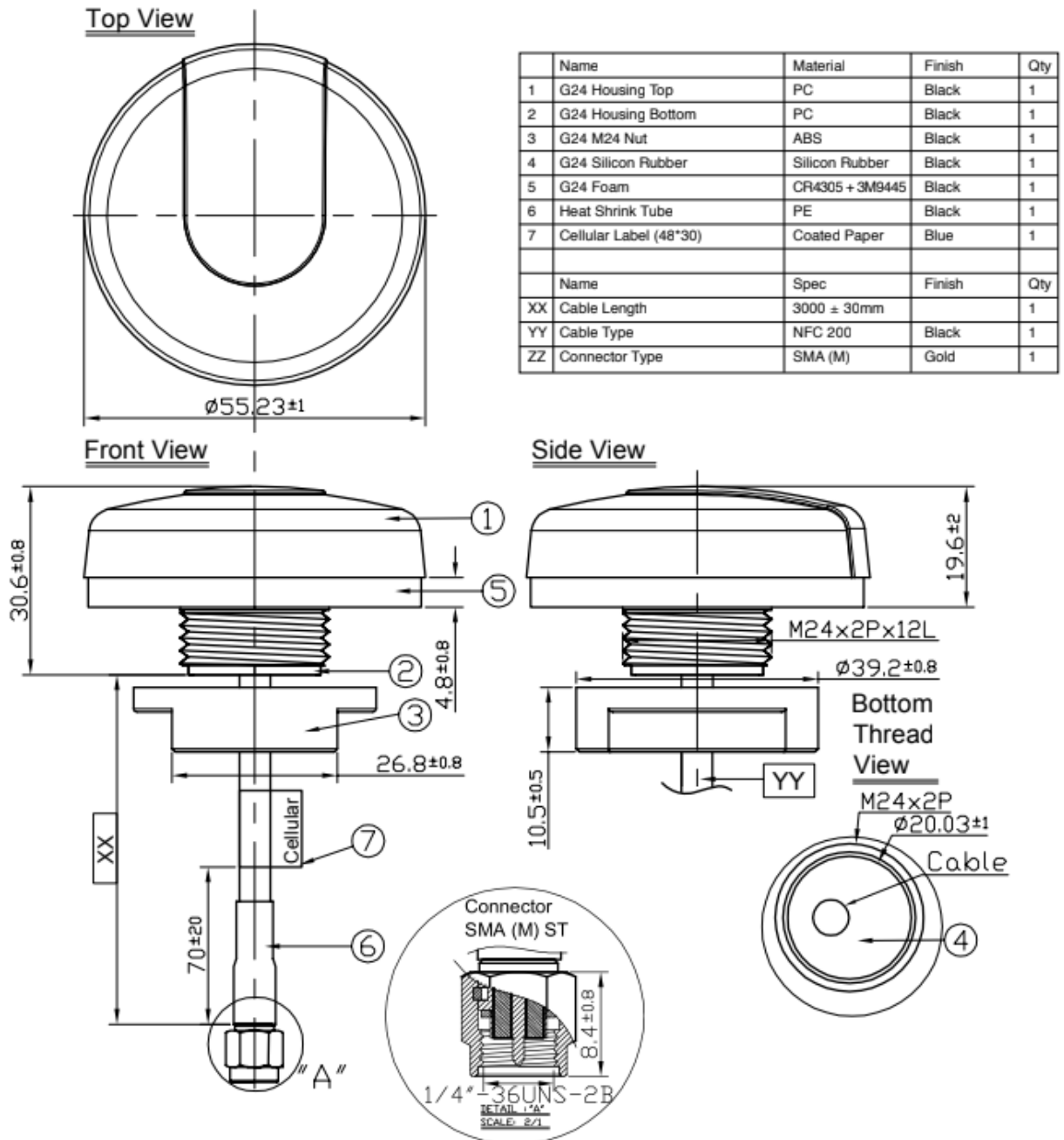

Mounting Instructions (unit:mm)

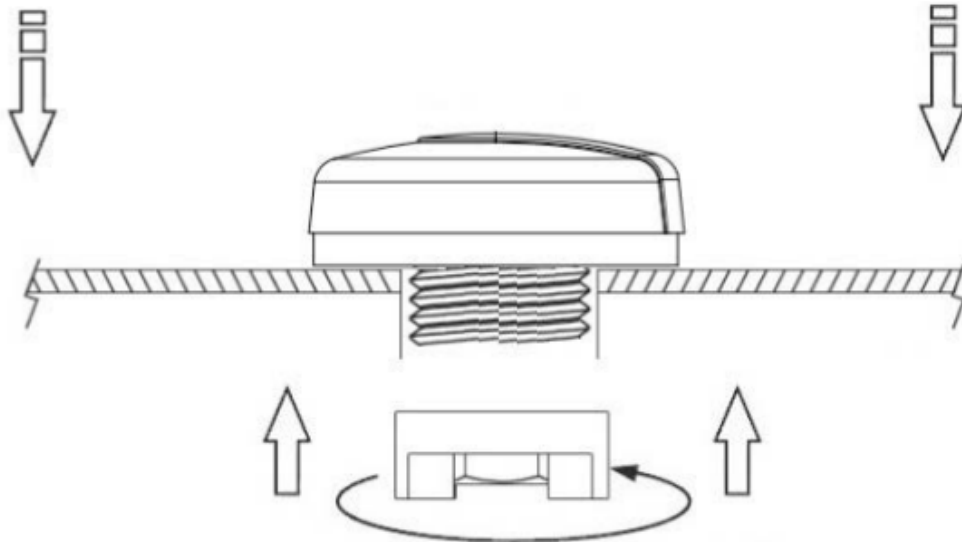

Recommended torque for Mounting is 3.92N·m
 Maximum torque for Mounting is 4.9N·m

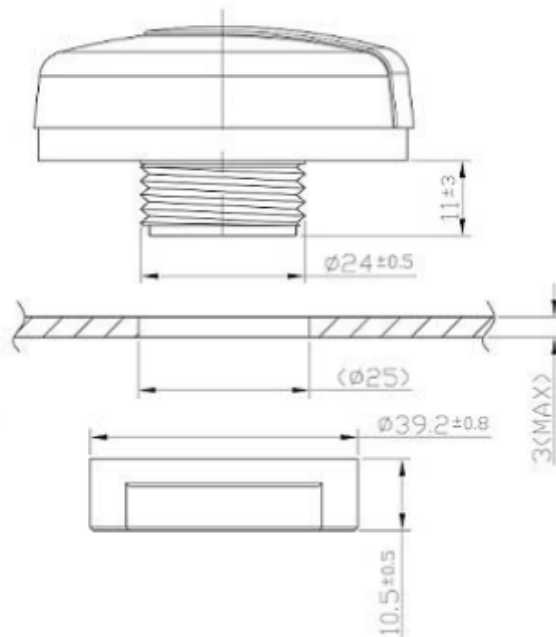

IXON makes no warranties based on the accuracy or completeness of the contents of this document and reserves the right to make changes to specifications and product descriptions at any time without notice. IXON reserves all rights to this document and the information contained herein. Reproduction, use or disclosure to third parties without express permission is strictly prohibited. Copyright © IXON B.V.
